

Network Coding-Based Protection Scheme for Elastic Optical Networks

W. Ramirez*[†], X. Masip-Bruin*, M. Yannuzzi[†], D. Montero[†], A. Martinez*[†], V. Lopez[‡]

*Advanced Network Architectures Lab (CRAAX), Technical University of Catalonia (UPC), Spain

[†]Networking and Information Technology Lab (NetIT Lab)

Emails: {wramirez, xmasip, yannuzzi, dmontero, annym}@ac.upc.edu

[‡]Telefonica I+D, Spain, vlopez@tid.es

Abstract—Optical technologies are the foundations supporting the current telecommunication network backbones due to the high speed transmissions achieved in fiber optical networks. Traditional optical networks consist of a fixed 50 GHz grid, resulting in a low optical spectrum (OS) utilization, specifically with transmission rates above 100 Gbps. This issue is magnified when network resilience capabilities are required. For instance, proactive protection solutions such as Dedicated Protection (DP) are widely used because of their low recovery time. However, a significant drawback of DP is its high utilization of optical bandwidth. Recently, optical networks are undergoing significant changes with the purpose of providing a flexible grid that can fully exploit the potential of optical networks. This has led to a new network paradigm termed as Elastic Optical Networks (EON). Moreover, a novel strategy referred to as network coding (NC) has been proposed with the aim of improving network throughput. In this paper, we propose a proactive protection scheme so-called E-DPNC* that combines both the advantages concerning network throughput offered by EON and NC, and the low recovery time of a DP scheme, in order to enable network resilience against optical link failures while also reducing the optical spectrum utilization. Our evaluation results show that our solution reduces the OS utilization by 41% compared with conventional protection schemes deployed on fixed grid scenarios.

Index Terms—Proactive Protection, Network Coding, Elastic Optical Networks.

I. INTRODUCTION

A major goal among network providers is to provide a diverse set of services including voice over IP (VoIP), video on demand (VoD), and others, in order to fulfill their customers needs. As a result, fiber optical technologies based on Wavelength Division Multiplexing (WDM) are commonly used as the transport medium to offer heterogeneous services requiring high bandwidth.

Nevertheless, WDM networks commonly use a 50 GHz fixed grid [1], which may result in an inefficient utilization of the optical spectrum (OS). To overcome this issue, a new network paradigm termed as Elastic Optical Network (EON) has been proposed, enabling enough flexibility to adapt the transponders bit rate to heterogeneous line rates [2]. This efficient utilization of the OS leads to a reduction in both equipment power consumption (OPEX cost), as well as equipment installation, i.e., transponders or optical fiber (CAPEX cost) [3].

The major building blocks of EON are the Orthogonal Frequency Division Multiplexing, Coherent Detection techniques,

and the exploitation of distinct modulation schemes. There are several studies in network research discussing the benefits of EON regarding energy efficiency compared to traditional optical networks [4], [5]. In addition, the studies found in [6], [7] focus on combining EON techniques with protection schemes for the purpose of reducing power consumption.

An additional goal for network providers is to enhance the resilience capabilities of their networks so as to increase the retainability of their offered services [8]. A common method to achieve network resilience is the use of proactive¹ protection schemes, such as 1+1 dedicated protection (DP). DP schemes are desired due to their low recovery time. However, the significant drawback of DP schemes boils down to the spare capacity availability [9], i.e., DP requires a significant amount of network resources to enable protection. In recent years, network coding (NC) techniques combined with a protection strategy have been a hot topic in network research, due to their promises of reducing the backup capacity utilization (network resources used for protection) of proactive protection schemes. In order to reduce the backup capacity utilization a network coding protection (NCP) scheme relies on coding (mixing) traffic. For more information related to NCP the reader is referred to [10-15].

However, the benefits of EON combined with NC techniques remains unaddressed, which is the rationale driving this paper. Thus, in this paper we derive a mathematical formulation for an NCP scheme based on a DP strategy augmented with the flexibility regarding the OS utilization enabled by EON. Our main objective is to propose a proactive protection scheme referred to as E-DPNC*, and evaluate its performance in two failure scenarios (single and multiple link failures). Specifically, we evaluate the OS used for link protection (OSP). OSP refers to the usage of network resources to enable protection. To ensure realistic findings the evaluated schemes were modeled over the Telefonica Spanish backbone optical network model [16].

The remainder of this paper is organized as follows. Section II describes in a nutshell related work on the issues addressed in this paper. Section III, introduces both operation and practical implementation of an NCP scheme. Section IV introduces the notation for the network model as well as the

¹The term Proactive refers to the simultaneous traffic transmission along the primary link and its backup path.

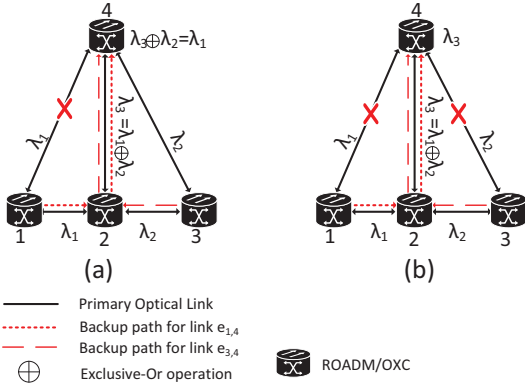

Figure 1. Operation of an NCP scheme: 1) single link failure; 2) double link failure.

mathematical formulation of the proposed scheme. Moreover, it also discusses the operation of proactive protection schemes in multiple link failure scenarios. Next, Section V provides a thorough comparison of the proposed scheme against other proactive protection solutions. Finally, conclusions and future work are presented in Section VI.

II. RELATED WORK

The pioneer work found in [17] introduced the advantages of NC to improve network throughput and also inspired other studies that evaluate NC techniques in different network scenarios, e.g., wireless, multicast. In recent years, many works came up focusing on combining NC and protection strategies to improve resilience in wired networks. For instance, the work found in [18] combines NC with p-cycles. Similar studies such as [11], [13] and [14], propose NCP schemes based on a DP strategy (these type of schemes are referred to as DPNC* in this paper). Other works evaluate the deployment of NCP schemes in MPLS networks [15].

In fact, the scheme proposed in this paper is inferred from the work done in [14]. We extend this work in order to meet two goals: 1) deploy a NCP scheme based on a DP strategy in an EON scenario (hereinafter referred to as E-DPNC* to assess the performance regarding the OSP utilization, and; 2) extend E-DPNC* for multiple link failure scenarios.

III. OPERATION OF A DPNC* SCHEME.

In this section we present the basic operation of a DPNC* scheme in both a fixed grid and an EON scenario, as well as the DPNC* advantages concerning the OSP utilization.

A. DPNC* scheme in fixed grid scenarios.

To illustrate the operation of a DPNC* we consider the directed graph topology $G(V, E)$ depicted in Fig. 1a, an optical network topology, such that V is the set of ROADMs/OXCs (Reconfigurable Optical Add-Drop Multiplexers/Optical Cross Connects), and E is the set of optical links. To protect the traffic traversing primary links $e_{1,4}$ and $e_{3,4}$, two disjoint backup paths are computed ($e_{1,2}, e_{2,4}$) and ($e_{3,2}, e_{2,4}$) for each primary link respectively. These two backup paths are

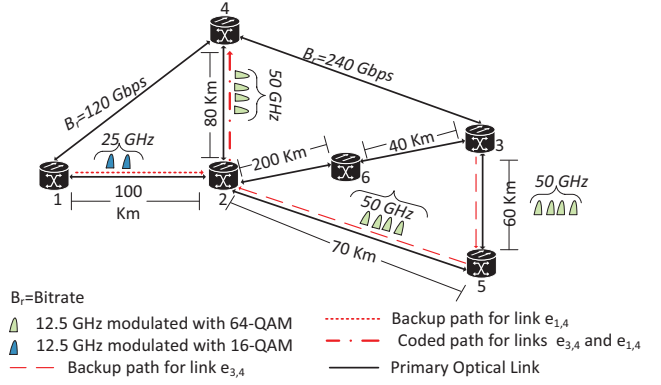

Figure 2. Operation of an NCP scheme in EON scenarios.

computed in such a way that they share at least one common link among them ($e_{2,4}$). In this way, OXC_2 is able to code the traffic sent along the protected links to minimize the number of optical wavelengths (λ) allocated to the protected traffic, i.e., $\lambda_3 = \lambda_1 \oplus \lambda_2$. As a result, the OSP utilization is 3λ . In a fixed WDM grid this yields to 150 GHz . On the contrary, if traditional DP is employed, 4λ (200 GHz) of OSP are allocated, since λ_1 and λ_2 are not coded. Thus, NC techniques significantly reduce the OSP utilization.

It is worth highlighting that in case of a failure affecting one of the protected links, such as $e_{1,4}$, OXC_4 can obtain λ_1 by doing $\lambda_3 \oplus \lambda_2 = \lambda_1$. Otherwise, in case of a simultaneous failure in both primary links ($e_{1,4}$ and $e_{3,4}$) it would be impossible to recover the traffic sent along these links, since OXC_4 would require either λ_1 or λ_2 to decode λ_3 , see Fig. 1b. In this type of multiple link failure scenario, conventional DP is more suitable. This issue is discussed in more detail in Section IV.C.

The link $e_{2,4}$ is referred to as the coding path, i.e., the path carrying the coded protected traffic. A coded traffic is obtained by mixing two or more traffic streams. We assume that all coding operations are based on the *exclusive-or operation* (XOR) and are done over $GF(2)$.

B. DPNC* scheme in EON Scenarios

In the previous subsection we have highlighted the operation of a DPNC* scheme in fixed grid scenarios. Nevertheless, in flexible grid setups there are several issues that need to be considered when deploying a DPNC* scheme. For instance, the OS allocation depends on the modulation format used, e.g., BPSK, QPSK, 16, 32 or 64-QAM. The modulation format is selected according to the transmission rate as well as the distance length (transparent reach), i.e., maximum distance without optical-electrical conversion. On this basis, the computation of disjoint paths must consider both the transmission rate of the primary links to be protected as well as the distance length of the backup paths. Table I shows the OS utilization for fixed and flexible (EON) grid WDM solutions according to the transparent reach and transmission rate [7]. Notice that an additional 10 GHz of guard band needs to be allocated to avoid adjacent channel interference.

Table I
OPTICAL SPECTRUM UTILIZATION FOR FLEXIBLE AND 50 GHz FIXED GRID WDM SOLUTION

Demand bit rate (Gbps)	Modulation Format	Transparent Reach (Km)	EON (GHz)	Fixed Grid Solution
<40	QPSK (1 subcarrier)	2000	12.5	50
$\geq 40, \leq 100$	16-QAM (1 or 2 subcarriers)	500	12.5-25	50
$> 100, < 200$	16-QAM (3 or 4 subcarriers)	500	37.5-50	100
$\geq 200, \leq 300$	32-QAM (4 or 5 subcarriers)	250	50-62.5	150
$\geq 200, \leq 300$	64-QAM (3 or 4 subcarriers)	125	37.5-50	150

To illustrate the operation of DPNC* scheme in EON scenarios we consider the network topology shown in Fig. 2. In this scenario, the traffic sent along the primary links $e_{1,4}$ and $e_{3,4}$ are modulated using a 16-QAM and 64-QAM schemes respectively. In order to protect the primary links $e_{1,4}$ and $e_{3,4}$ with DPNC* the following configuration is enabled: 1) The backup paths ($e_{1,2}$), and ($e_{3,5}, e_{5,2}$) are computed, and; 2) the link $e_{2,4}$ is configured as the coding path. With this configuration the OSP utilization –according to the spectrum slicing shown in Table 1– is $175 GHz$: $25 GHz$ allocated to path $e_{1,2}$, $100 GHz$ allocated to path $e_{3,5}, e_{5,2}$, and $50 GHz$ allocated to the coding path ($e_{2,4}$). This configuration is the most suitable according to both the geographic distance of the backup paths, and the demand bit rate traversing the primary links. Otherwise, if the backup path ($e_{3,6}, e_{6,2}$) is used for link $e_{3,4}$, around $\approx 180 GHz$ need to be allocated because the transparent reach for a optical signal modulated with a 64-QAM scheme is 125 Km (kilometers). Note that the distance length of link $e_{6,2}$ is 200 Km, hence, a 32-QAM modulation scheme must be used. Moreover, if a fixed grid solution is used for the scenario depicted in Fig. 2 the OSP utilization is $550 GHz$. A higher OSP utilization ($650 GHz$) is obtained if conventional DP is used instead of DPNC*. Therefore, DPNC* jointly with EON (E-DPNC*) provides a significant reduction of the OSP. The remainder of this paper is devoted to describe in detail the deployment of a E-DPNC* scheme.

C. Practical Implementation of NCP in Elastic Optical Networks.

Conventional protection schemes such as DP have been widely and successfully deployed in real optical network scenarios [19]. Moreover, the future standardization of EON seems plausible in the coming years. Thereby, it can be stated that the only limitation concerning the deployment of NCP schemes in EON is related to all-optical XOR gates. The optical implementation of all-optical XOR gates is widely studied in network research [20]. All-optical XOR gates are typically based on Semiconductor Optical Amplifiers (SOA) as shown in Fig. 3. SOAs offer low-power consumption, easy deployment and short-latency.

Notice that the execution of XOR operations can be done at line speed for transmission above $10 Gbps$ and up to $100 Gbps$, with modulation schemes such as QPSK. Therefore, from a practical perspective, the deployment of NCP schemes in a near future seems feasible. It must be noticed that to the best of our knowledge, at present, the practical implementation of optical XOR operations of optical signals with different

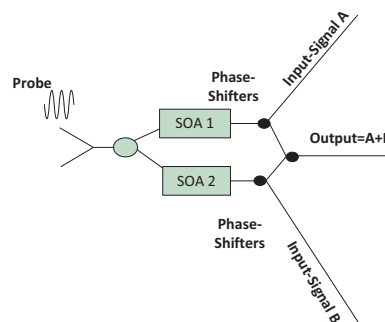

Figure 3. All-optical XOR gate based on Semiconductor Optical Amplifiers (SOA).

modulation schemes such as BPSK and QPSK is possible [21]. However, the all-optical XOR of other modulation schemes needs further study.

IV. NETWORK MODEL AND PROBLEM FORMULATION

In this section we describe the proposed scheme referred to as E-DPNC*, which is an extension of DPNC* with the aim to enable link protection in single and multiple link failure scenarios. In addition, we describe the mathematical formulation and operation of the proposed scheme.

With the aim of reducing the computation time required to deploy an E-DPNC* scheme we define the concepts of protection group and subgroup. A protection group is a set of traffic demands traversing a link, and a protection subgroup is a possible combination of traffic demands sent along a link for a given protection group. We create protection groups based on the traffic demands destination and bit-rate, because as described in [14], [11], it is more suitable to protect links with common terminal vertices. Hence, a protection group only contains traffic demands with the same destination, e.g., traffic sent along links $e_{1,2}, e_{3,2}, e_{4,2}$. For more information related to protection groups the reader is referred to [22], [13].

A. Network Model

The optical network is represented as a directed graph $G(V, E)$, such that V is the set of nodes and E is the set of edges. All nodes are assumed to be flexible ROADMs/OXCs (EON enabled), while all edges model point-to-point optical links. We do not consider the link capacity constraint because

Table II
NOTATION LIST USED FOR THE E-DPNC* PROBLEM

Symbol	Meaning
W	Set of Protection Groups
g	A Protection Group, such that $g \in W$
s	Protection Subgroup, such that $s \in g$
$\xi()$	The OS reduction achieved by the use of network coding
$\delta(j, d)$	The OS required to route a traffic demand along a given link
$\iota(j)$	The length of link j (kilometers)
$D_1(d)$	$D_1(d) = 1$ if demand $d < 40$ Gbps, otherwise 0
$D_2(d)$	$D_2(d) = 1$ if demand $40 \text{ Gbps} \leq d \leq 100 \text{ Gbps}$, otherwise 0
$D_3(d)$	$D_3(d) = 1$ if demand $100 \text{ Gbps} < d < 200 \text{ Gbps}$, otherwise is 0
$D_4(d, \iota(j))$	$D_4(d) = 1$ if demand $200 \text{ Gbps} \leq d \leq 300 \text{ Gbps}$ and the length of link j is > 125 and $j \leq 250$, otherwise is 0
$D_5(d, \iota(j))$	$D_5(d) = 1$ if demand $200 \text{ Gbps} \leq d \leq 300 \text{ Gbps}$ and the length of link j is ≤ 125 , otherwise is 0
x_j^d	$x_j^d = 1$ if link j is the primary link for demand d , 0 otherwise
y_j^d	$y_j^d = 1$ if link j belongs to the protection path of demand d , otherwise is 0
$y'_j{}^d$	$y'_j{}^d = 1$ if link j belongs to the second protection path of demand d , otherwise is 0
z^s	$z^s = 1$ if protection subgroup s is protected, 0 otherwise
R_d	Receiver Node of demand d
S_d	Source Node of demand d

we focus on the minimum OSP usage. Moreover, the network is at least two-path-connected, i.e., for every source-destination pair there are two link-disjoint paths. Otherwise, it is not possible to employ a DP strategy.

For the purpose of providing a cost comparison, we define the protection gain (P_{gain}) as the optical spectrum saved when E-DPNC* is used:

$$P_{gain} = \frac{\zeta_{SDP} - \zeta_{E-DPNC*}}{\zeta_{SDP}} \quad (1)$$

In Equation (2) ζ_{SDP} and $\zeta_{E-DPNC*}$ stand for the OS utilization enabling link protection (OSP) for DP and E-DPNC* scheme respectively.

B. Mathematical Model

We define the E-DPNC* problem as the *computation of a protection path for a given primary link in such a way that the coding of traffic is maximized, as long as, the OSP utilization is minimized.*

A mathematical model for the E-DPNC* problem can be formulated as an Integer Linear Program (ILP). Notice that the E-DPNC* problem is a sub-problem of the 1+1 DP formulation proved to be NP-Complete by authors in [23].

The notation used for this model is depicted in Table 2. The objective function is defined as given a graph $G(E, V)$ (representing an optical topology) minimize the OSP using a

DPNC* scheme in an EON scenario. The mathematical model is as follows:

$$\min \sum_{s \in g} z^s \times \left[\sum_{j \in E} \sum_{d \in s} (\delta(j, d) \times y_j^d) - \xi(s) \right] \quad (2)$$

$$s.t. \quad x_j^d + y_j^d \leq 1 \quad \forall s \in g, \forall d \in s, j \in E \quad (3)$$

$$\sum_{j \in E} (y_j^{d_1} + y_j^{d_2}) \geq |s| \quad (4)$$

$$\forall s \in g, \forall d_1 \neq d_2, d_1, d_2 \in s$$

$$\sum_{\forall (v,u) \in E} x_{(v,u)}^d - \sum_{\forall (v,u) \in E} x_{(u,v)}^d = \begin{cases} 1, & \text{if } v = R_d \\ -1, & \text{if } v = S_d \\ 0, & \text{otherwise} \end{cases} \quad (5)$$

$$\forall d \in D, v \in V$$

$$\sum_{\forall (v,u) \in E} y_{(v,u)}^d - \sum_{\forall (v,u) \in E} y_{(u,v)}^d = \begin{cases} 1, & \text{if } v = R_d \\ -1, & \text{if } v = S_d \\ 0, & \text{otherwise} \end{cases} \quad (6)$$

$$\forall d \in D, v \in V$$

$$\sum_{s \in g} z^s = 1 \quad (7)$$

$$\delta(j, d) = 12.5D_1(d) + 25D_2(d) + 37.5D_3(d) + 50D_4(d, \iota(j)) + 62.5D_5(d, \iota(j)) \quad (8)$$

$$\forall d \in s, j \in E$$

Equation (2) is the objective function which is defined as the OS needed to route the traffic demand along a protection path, minus the OS saved by the throughput improvement achieved by the use of network coding.

Moreover, Equation (3) ensures link-disjointness between the primary link and the backup path allocated for demand d . Equation (4) specifies that to enable traffic coding the protection paths for each demand belonging to a protection subgroup must have at least one link in common among them. Equations (5) and (6) formulate the flow conservation constraints for the primary links and the backup paths respectively. Equation (7) defines that only one protection subgroup belonging to a specific protection group will be protected. Notice that a protection subgroup is not unique, i.e., two or more protection subgroups share one or more demands (d). Finally, Equation (7) captures the spectrum assignment.

C. Multiple Link Failure Scenarios

Despite multiple simultaneous link failure scenarios are not as common as single link failure scenarios, they must be also addressed by a protection scheme since they can lead to a high amount of traffic loss. This is proven by several works already available in the literature regarding multiple link failure scenarios caused by natural disasters, power outages or by malicious attacks [24], [25], [26].

A DPNC* scheme may not be feasible under certain type of multiple link failure scenarios, i.e., two or more links fail simultaneously. By feasible, we refer to the cases where $P_{gain} > 0$, i.e., the OSP utilization is less compared to the OSP utilization when using a DP scheme, see Equation (2). A DPNC* scheme can recover affected traffic as long as the affected traffic destination (v_t) can decode the protected traffic. For this purpose, $|\sigma_{v_t}| - 1$ optical signals need to be received at the affected traffic destination, where σ_{v_t} is the amount of optical traffic destined to node v_t . In this paper, we consider a protected traffic as the total traffic traversing an optical link.

Moreover, we distinguish three types of multiple link failure scenarios (A, B, C). We consider that for each failure scenario the graph maintains its connectivity.

For *Failure Scenario A* (see Fig. 4a) two or more primary links fail. A DPNC* strategy can efficiently recover ($P_{gain} > 0$) the affected traffic traversing the failed optical link, as long as the protection path of the failed links are link disjoint, and no more than two primary links with the same terminal vertex fail. *Failure Scenario A* is formulated as follows:

$$\sum_{j \in L'} \Gamma_j^s \leq 1 \quad \forall s \in g \quad (9)$$

$$\sum_{d \in D'} x_j^d + y_k^d = 1 \quad \forall j, k \in L', k \neq j \quad (10)$$

Note that, $\Gamma_j^s = 1$ if link j belongs to protection subgroup s , otherwise $\Gamma_j^s = 0$. Moreover, L' and D' are the set of failed links and affected traffic demands respectively.

For *Failure Scenario B* (see Fig. 4b) two or more links fail simultaneously, such that at most two primary links with the same terminal vertex fail, and the terminal vertex indegree of the failed links is greater than one. In addition, a failed link does not belong to the protection path of another failed link. This scenario is formulated as follows.

$$\sum_{j \in L'} \Gamma_j^s \leq 2, \quad \forall s \in g \quad (11)$$

$$\sum_{d \in D'} x_j^d + y_k^d = 1 \quad \forall j, k \in L', k \neq j \quad (12)$$

In *Failure Scenario B*, DPNC* can recover the failed traffics, but a strategy (selection of protection paths) different from the presented in section IV. B must be done, see Fig. 4b. However, DPNC* cannot efficiently recover the affected traffic (with $P_{gain} > 0$), because a conventional DP scheme do not need to decode protected traffic, as described in section III.A.

In *Failure Scenario C* (see Fig. 4c), two or more links fail simultaneously, but neither of the failed links have a terminal

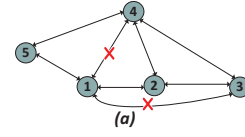

*		Source				
Destination	1	2	3	4	5	
1	0	$T_{2,4}$	0	0	$T_{5,4}$	
2	$T_{1,4}$	0	$T_{3,4}$	0	0	
3	0	0	0	0	0	
4	$T_{1,4}, (T_{2,4} \oplus T_{5,4})$	$T_{2,4}, (T_{1,4} \oplus T_{3,4})$	$T_{3,4}$	0	$T_{5,4}$	
5	0	0	0	0	0	

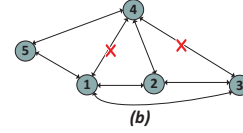

*		Source				
Destination	1	2	3	4	5	
1	0	$T_{2,4}, T_{3,4}, T_{5,4}$	0	0	$T_{5,4}$	
2	$T_{1,4}, (T_{5,4} \oplus T_{2,4} \oplus T_{3,4})$	0	$T_{3,4}$	0	0	
3	0	0	0	0	0	
4	$T_{1,4}, (T_{2,4} \oplus T_{5,4})$	$T_{2,4}, (T_{1,4} \oplus T_{3,4}), T_{5,4}$	$T_{3,4}$	0	$T_{5,4}, (T_{1,4} \oplus T_{2,4})$	
5	$T_{2,4} \oplus T_{3,4}$	0	0	0	0	

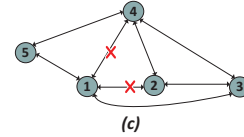

*		Source				
Destination	1	2	3	4	5	
1	$T_{1,4}$	$T_{2,4}$	0	0	$T_{5,4}$	
2	0	0	$T_{3,4} \oplus T_{1,4}$	0	0	
3	$(T_{1,4} \oplus T_{3,4}), (T_{2,4} \oplus T_{5,4})$	$T_{1,4}$	0	0	0	
4	$T_{1,4}, (T_{2,4} \oplus T_{5,4})$	$T_{2,4}, (T_{1,4} \oplus T_{3,4})$	$T_{3,4}$	0	$T_{5,4}$	
5	0	0	$T_{3,4}$	0	0	

$T_{u,v}, T'_{u,v}$ Traffic Demand, and Replica of a Traffic Demand sent along link u,v respectively

* Traffic Matrix defining the traffic demands sent along primary links and backup paths

\oplus Exclusive-Or operation

Figure 4. Multiple link failure scenarios: 1) Scenario A; 2) Scenario B; 3) Scenario C.

vertex in common, and at most one of the failed links is part of the backup path of another failed link. In this scenario a DPNC* scheme can efficiently recover the affected traffic. This scenario is formulated as follows.

$$\sum_{j \in L'} \Gamma_j^s = 0, \quad \forall s \in g \quad (13)$$

$$\sum_{d \in D'} x_j^d + y_k^d \leq 2 \quad \forall j, k \in L' \quad (14)$$

To address *Failure Scenario C* Equation (3) must be modified as follows.

$$\sum_{j \in E} x_j^d + y_j^d + y'_j{}^d = 1 \quad \forall s \in g, \forall d \in s \quad (15)$$

Note that $y_j^d \in \{0, 1\}$ if link j belongs to the second protection path for demand d . Moreover, the following constraints must be added to the E-DPNC* problem.

$$\sum_{j \in E} (y_j^d + y'_j{}^d) > |s| \quad (16)$$

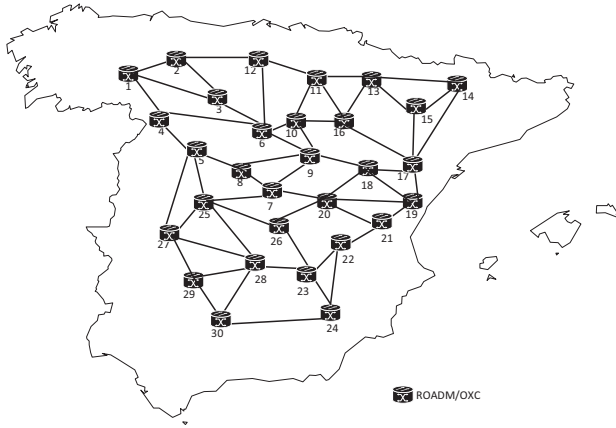

Figure 5. Telefonica Spanish backbone topology.

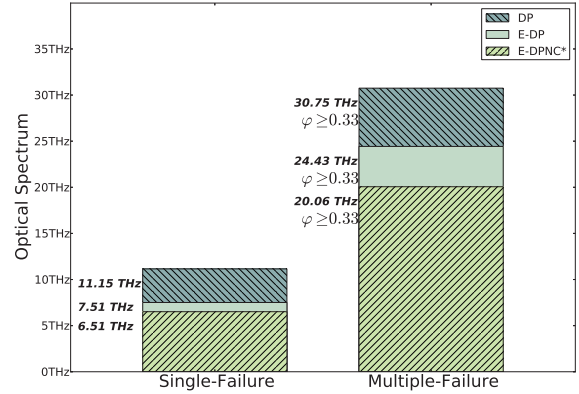

Figure 6. Comparison of the total OSP utilization on single and multiple link failure scenarios.

$$\forall s \in g, \forall d \neq d_2, d \in s$$

$$\sum_{\forall(v,u) \in E} y'_{(v,u)}^d - \sum_{\forall(v,u) \in E} y''_{(u,v)}^d = \begin{cases} 1, & \text{if } v = R_d \\ -1, & \text{if } v = S_d \\ 0, & \text{otherwise} \end{cases} \quad (17)$$

$$\forall d \in D, v \in V$$

Equation (16) defines the conditions to enable traffic coding for the second protection path. Equation (17) defines the flow conservation for the second protection path. Notice that Equation (15) may not be fulfilled, since it depends on topology characteristics such as edge connectivity, i.e., maximum number of link-disjoint paths. Thus, Equation (15) should not be considered and the following constraints must be added to the E-DPNC* problem:

$$\sum_{j \in E} x_j^d + y_j^d = 1 \quad \forall s \in g, \forall d \in s \quad (18)$$

$$\sum_{j \in E} x_j^d + y_j^d = 1 \quad \forall s \in g, \forall d \in s \quad (19)$$

$$\left(\sum_{j \in E} y_j^d \times y_j^d \right) \times \frac{1}{\left(\sum_{k \in E} y_k^d + y_k^d \right)} \geq \varphi \quad (20)$$

$$\forall s \in g, \forall d \in s$$

Equation (18) and (19) defines link-disjointness between primary paths and protection paths. Finally, we define φ as the *protection grade*, (see Equation (20)) which is the link-disjoint degree among the protection path, and second protection path for a certain protection subgroup. The *protection grade* was set to 0.33, hence, a protection path and a second protection path must be at least 33% link-disjoint from each other.

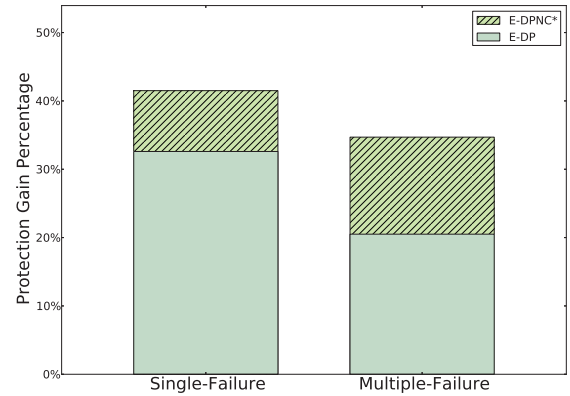

Figure 7. Protection Gain comparison.

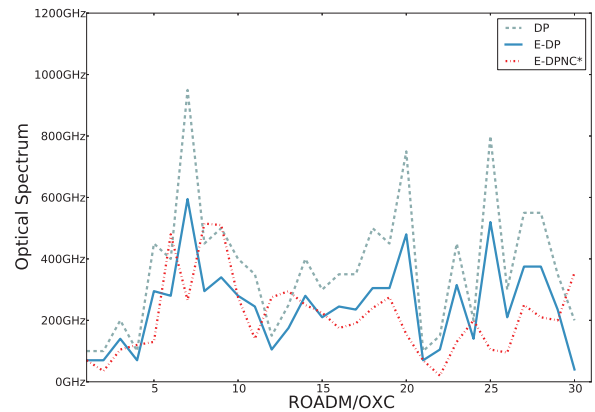

Figure 8. Comparison of the OSP utilization per ROADM/OXC in single link failure scenarios.

V. NUMERICAL RESULTS

In this section we compared the performance of an E-DPNC* scheme with both DP for a fixed grid (assuming 50GHz channels), and for a flexible spectrum (E-DP) configuration respectively. The evaluation environment was built using the Python graph library NetworkX [27]. In this performance evaluation we consider the Telefonica Spanish backbone optical network model shown in Fig. 5, with a traffic matrix with a total traffic volume of 1.20 Tbits [16].

Figure 6 depicts the total OSP utilization for single, and multiple link failure scenarios (*Failure Scenario C*). In addition, Fig. 7, depicts the P_{gain} for both E-DP and E-DPNC* schemes on single and multiple link failure scenarios. Note that a OSP reduction of 32.6 and 20.5 can be obtained with E-DP compared with DP for single and multiple link failure scenarios respectively. Nevertheless, a higher OSP reduction is obtained when NC techniques are used. With E-DPNC* the P_{gain} is 41.5% and 34.7% for single and multiple link failure scenarios respectively. Therefore, the use of NC techniques improves the P_{gain} of E-DP scheme by 8.9 for single link failures and 14.2% for multiple link failures.

Moreover, Fig. 8 shows the OSP utilization per ROADM/OXC for each of the evaluated protection schemes on single failure scenarios. The OSP utilization for a specific ROADM/OXC strongly depends on the routing and wavelength assignment algorithm used, and also on the traffic matrix. Furthermore, for the specific case of a E-DPNC* scheme, a intuitive thought is to assume that nodes with a high degree centrality (C_d) [28], which neighbors (direct connected nodes) also have a high C_d tend to have a high optical spectrum utilization, such as ROADM/OXCs 9, 10 and 6, see. Fig. 9. This is because a protection group size as described in Section III depends on the indegree of a given node. Thus, whether a node x is highly connected and its neighbors are too, x will be probably selected as coding node, i.e., a node that codes (mix) traffic; hence, it will allocate optical resources to protected traffic. In a similar manner, Fig. 9 depicts the OSP utilization per ROADM/OXC for multiple link failure scenarios (*Failure Scenario C*).

Based on the evaluation results presented in this section, it can be concluded that a proactive protection scheme such as E-DPNC* scheme, that combines the advantages provided by EON and network coding concerning OS utilization, outperforms conventional proactive protection schemes.

VI. CONCLUSIONS AND FUTURE WORK

In this paper we study the deployment of network coding protection schemes based on a DP strategy (DPNC*) in Elastic Optical Network (EON) scenarios. We show an ILP formulation and an algorithm for the selection of backup paths that enable traffic coding in order to reduce the optical spectrum utilization required to enable link protection (OSP). In addition, we propose a proactive protection scheme referred to as E-DPNC* enabling link protection in single and multiple link failure scenarios. The proposed scheme is based on NC techniques combined with flexible ROADM/OXC nodes. The evaluation results show that E-DPNC* schemes significantly

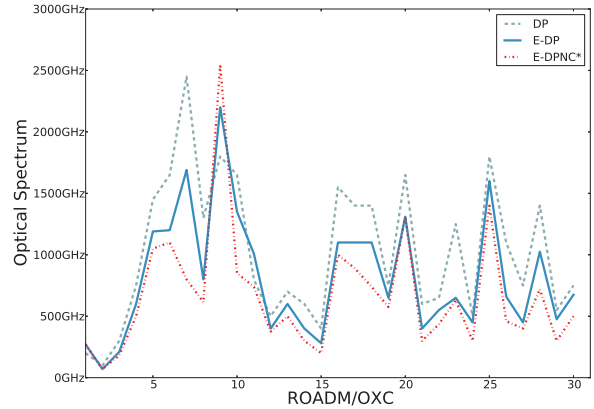

Figure 9. Comparison of the OSP utilization per ROADM/OXC in multiple link failure scenarios.

reduce the OSP utilization compared with other traditional proactive protection schemes deployed on fixed ROADM/OXC nodes. As a future line of work, we intend to study the deployment of DPNC* schemes on multi-domain optical networks.

ACKNOWLEDGMENTS

This work was supported by the Spanish Ministry of Economy under contract TEC2012-34682, and the Catalan Research Council (CIRIT) under contract 2009 SGR1508.

REFERENCES

- [1] Spectral grids for WDM applications: DWDM frequency grid, ITU-T Recommendation G.694.1 available at <http://www.itu.int.>, *ITUT Std.*
- [2] O. Gerstel, M. Jinno, A. Lord, and S. J. B. Yoo, "Elastic optical networking: a new dawn for the optical layer?" *Communications Magazine, IEEE*, vol. 50, no. 2, pp. s12–s20, 2012.
- [3] M. Jinno, T. Ohara, Y. Sone, A. Hirano, O. Ishida, and M. Tomizawa, "Elastic and adaptive optical networks: possible adoption scenarios and future standardization aspects," *Communications Magazine, IEEE*, vol. 49, no. 10, pp. 164–172, 2011.
- [4] S. Zhang and B. Mukherjee, "Energy-efficient dynamic provisioning for spectrum elastic optical networks," in *Communications (ICC), 2012 IEEE International Conference on, 2012*, pp. 3031–3035.
- [5] A. Klekamp, U. Gebhard, and F. Ilchmann, "Efficiency of adaptive and mixed-line-rate IP over DWDM networks regarding CAPEX and power consumption [Invited]," *Optical Communications and Networking, IEEE/OSA Journal of*, vol. 4, no. 11, pp. B11–B16, 2012.
- [6] A. Muhammad, P. Monti, I. Cerutti, L. Wosinska, P. Castoldi, and A. Tzanakaki, "Energy-Efficient WDM Network Planning with Dedicated Protection Resources in Sleep Mode," in *Global Telecommunications Conference (GLOBECOM 2010), 2010 IEEE, 2010*, pp. 1–5.
- [7] J. Lopez, Y. Ye, V. Lopez, F. Jimenez, R. Duque, P. Krummrich, F. Musumeci, M. Tornatore, and A. Pattavina, "Traffic and power-aware protection scheme in Elastic Optical Networks," in *Telecommunications Network Strategy and Planning Symposium (NETWORKS), 2012 XVth International, 2012*, pp. 1–6.
- [8] J. Topolcai, P. Cholda, T. Cinkler, K. Wajda, A. Jajszczyk, A. Autenrieth, S. Bodamer, D. Colle, G. Ferraris, H. Lonsethagen, I.-E. Svinunet, and D. Verchere, "Quality of resilience (QoR): NOBEL approach to the multi-service resilience characterization," in *Broadband Networks, 2005. BroadNets 2005. 2nd International Conference on, 2005*, pp. 1328–1337 Vol. 2.

- [9] P. Cholda, A. Mykkeltveit, B. Helvik, O. Wittner, and A. Jajszczyk, "A survey of resilience differentiation frameworks in communication networks," *Communications Surveys Tutorials*, IEEE, vol. 9, no. 4, pp. 32–55, 2007.
- [10] A. Kamal, A. Ramamoorthy, L. Long, and S. Li, "Overlay Protection Against Link Failures Using Network Coding," *Networking*, IEEE/ACM Transactions on, vol. 19, no. 4, pp. 1071–1084, aug. 2011.
- [11] A. Mukhtadir, A. Jose, and E. Oki, "An Optimum Mathematical Programming Model for Network-Coding Based Routing with 1+1 Path Protection," in *World Telecommunications Congress (WTC)*, 2012, march 2012, pp. 1–5.
- [12] S. Nazim and E. Ayanoglu, "Network Coding-Based Link Failure Recovery over Large Arbitrary Network." *Globecom*, 2013.
- [13] H. Overby, G. Biczok, P. Babarczi, and J. Tapolcai, "Cost comparison of 1+1 path protection schemes: A case for coding," in *Communications (ICC)*, 2012 IEEE International Conference on, pp. 3067–3072.
- [14] W. Ramirez, X. Masip-Bruin, M. Yannuzzi, R. Serral-Gracia, and A. Martinez, "An Efficient Protection Strategy Using Multiple Network Coding," in *International Workshop on Network Management Innovations, SACONET 2013*, Paris, France., June 2013.
- [15] P. Babarczi, J. Tapolcai, A. Pasic, S. Darehchi, and P.-H. Ho, "New addressing scheme to increase reliability in MPLS with network coding," in *Design of Reliable Communication Networks (DRCN)*, 2013 9th International Conference on the, 2013, pp. 36–43.
- [16] "Telefonica network planning report [Internal]." *Tech. Rep.*, 2013.
- [17] A. Agarwal and M. Charikar, "On the advantage of network coding for improving network throughput," in *Information Theory Workshop*, 2004. IEEE, 2004, pp. 247–249.
- [18] M. Belzner, H. Haunstein, and A. van Wijngaarden, "On the Performance of Network Coding with Protection Cycles," in *Communications (ICC)*, 2011 IEEE International Conference on, june 2011, pp. 1–6.
- [19] O. Gerstel and R. Ramaswami, "Optical layer survivability: a post-bubble perspective," *Communications Magazine*, IEEE, vol. 41, no. 9, pp. 51–53, 2003.
- [20] M. Zhang, L. Wang, and P. Ye, "All optical XOR logic gates: technologies and experiment demonstrations," *Communications Magazine*, IEEE, vol. 43, no. 5, pp. S19–S24, 2005.
- [21] D. Kong, Y. Li, H. Wang, S. Zhou, J. Zang, J. Zhang, J. Wu, and J. Lin, "All-optical XOR gates for QPSK signal based optical networks," *Electronics Letters*, vol. 49, no. 7, pp. 486–488, 2013.
- [22] W. Ramirez, X. Masip-Bruin, M. Yanuzzi, E. Marin-Tordera, A. Martinez, and V. Lopez, "A Techno-Economic Study of Proactive Protection Schemes in Multi-Layer Network Scenarios," *Technical Report*: <http://www.ac.upc.edu/app/research-reports/html/RR/2013/58.pdf>, 2013.
- [23] P. Babarczi, G. Biczok, H. Overby, J. Tapolcai, and P. Soproni, "Realization strategies of dedicated path protection: A bandwidth cost perspective," *Computer Networks*, vol. 57, no. 9, pp. 1974 – 1990, 2013. [Online]. Available: <http://www.sciencedirect.com/science/article/pii/S1389128613001011>
- [24] M. Manzano, J.-L. Marzo, E. Calle, and A. Manolovay, "Robustness analysis of real network topologies under multiple failure scenarios," in *Networks and Optical Communications (NOC)*, 2012 17th European Conference on, 2012, pp. 1–6.
- [25] A. Kwasinski, "Effects of notable natural disasters from 2005 to 2011 on telecommunications infrastructure: Lessons from on-site damage assessments," in *Telecommunications Energy Conference (INTELEC)*, 2011 IEEE 33rd International, 2011, pp. 1–9.
- [26] D. of Homeland-Security, "Pandemic Influenza Impact on Communications Networks Study, unclassified, Department of Homeland Security (DHS)," December 2007.
- [27] <http://networkx.github.io/>, [Online; accessed October-2013].
- [28] S. Borgatti and M. Everett, "A Graph-theoretic perspective on centrality," *Social Networks*, vol. 28, no. 4, pp. 466–484, Oct. 2006. [Online]. Available: <http://dx.doi.org/10.1016/j.socnet.2005.11.005>